

# ELECTRICAL

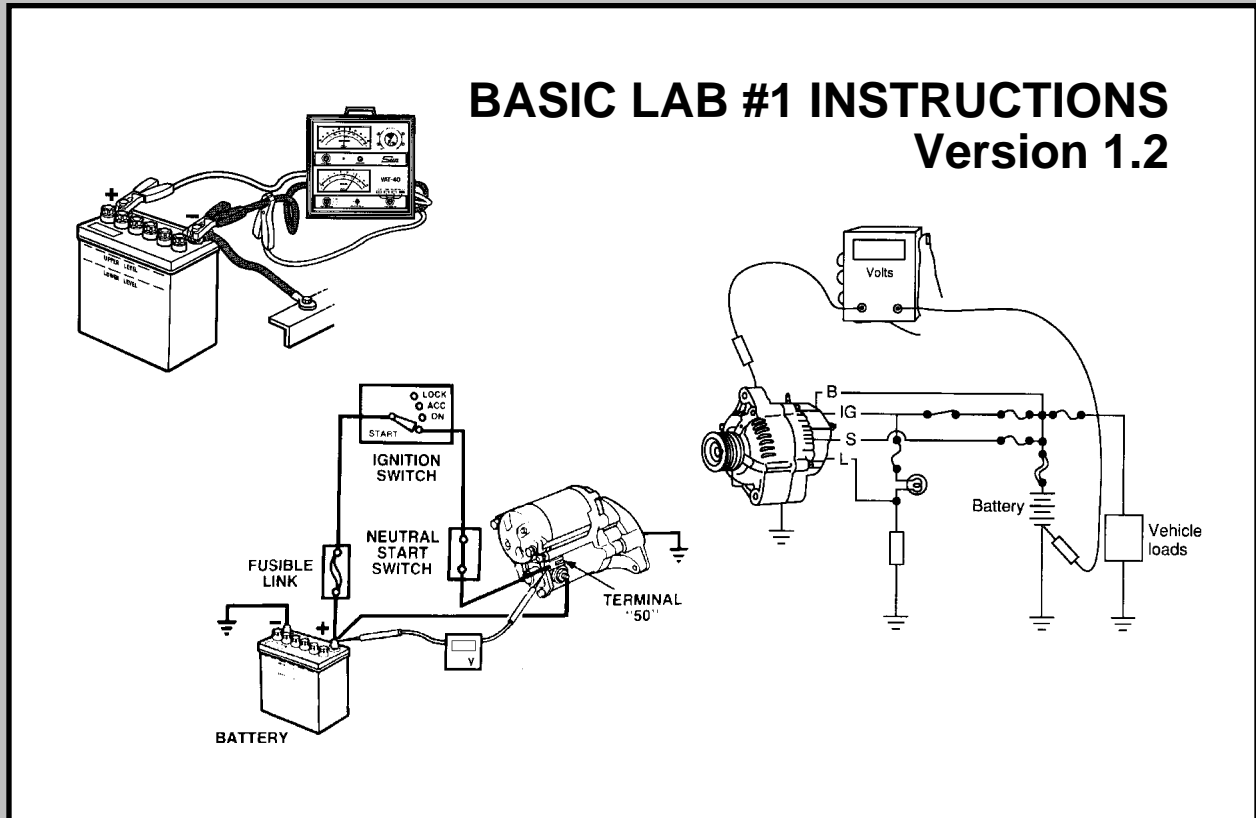

## ***BATTERY, STARTING, & CHARGING ON-CAR LAB INSTRUCTIONS***

<http://www.autoshop101.com>

Blank Page

All pages in this booklet  
should be double sided

## VISUAL INSPECTION

Battery service should begin with a thorough visual inspection. This may reveal simple, easily corrected problems, or problems that might require battery replacement.

1. Check for cracks in the battery case and for broken terminals. Either may allow electrolyte leakage. The battery must be replaced.
2. Check for cracked or broken cables or connections. Replace, as needed.
3. Check for corrosion on terminals and dirt or acid on the case top. Clean the terminals and case top with a mixture of water and baking soda or ammonia. A wire brush is needed for heavy corrosion on the terminals.
4. Check for a loose battery hold-down and loose cable connections. Tighten, as needed.
5. Check the level of electrolyte. The level can be viewed through the translucent plastic case or by removing the vent caps and looking directly into each cell. The proper level is 1/2" above the separators. If necessary, add distilled water to each low cell. Avoid overfilling. When water is added, always charge the battery to make sure the water and acid mix.
6. Check for cloudy or discolored electrolyte caused by overcharging or vibration. This could cause high self discharge. The problem should be corrected and the battery replaced.
7. Check the condition of plates and separators. Plates should alternate dark (+) and light (-). If all are light, severe undercharging is indicated. Cracked separators may allow shorts. The battery should be replaced. An undercharging problem should be corrected.

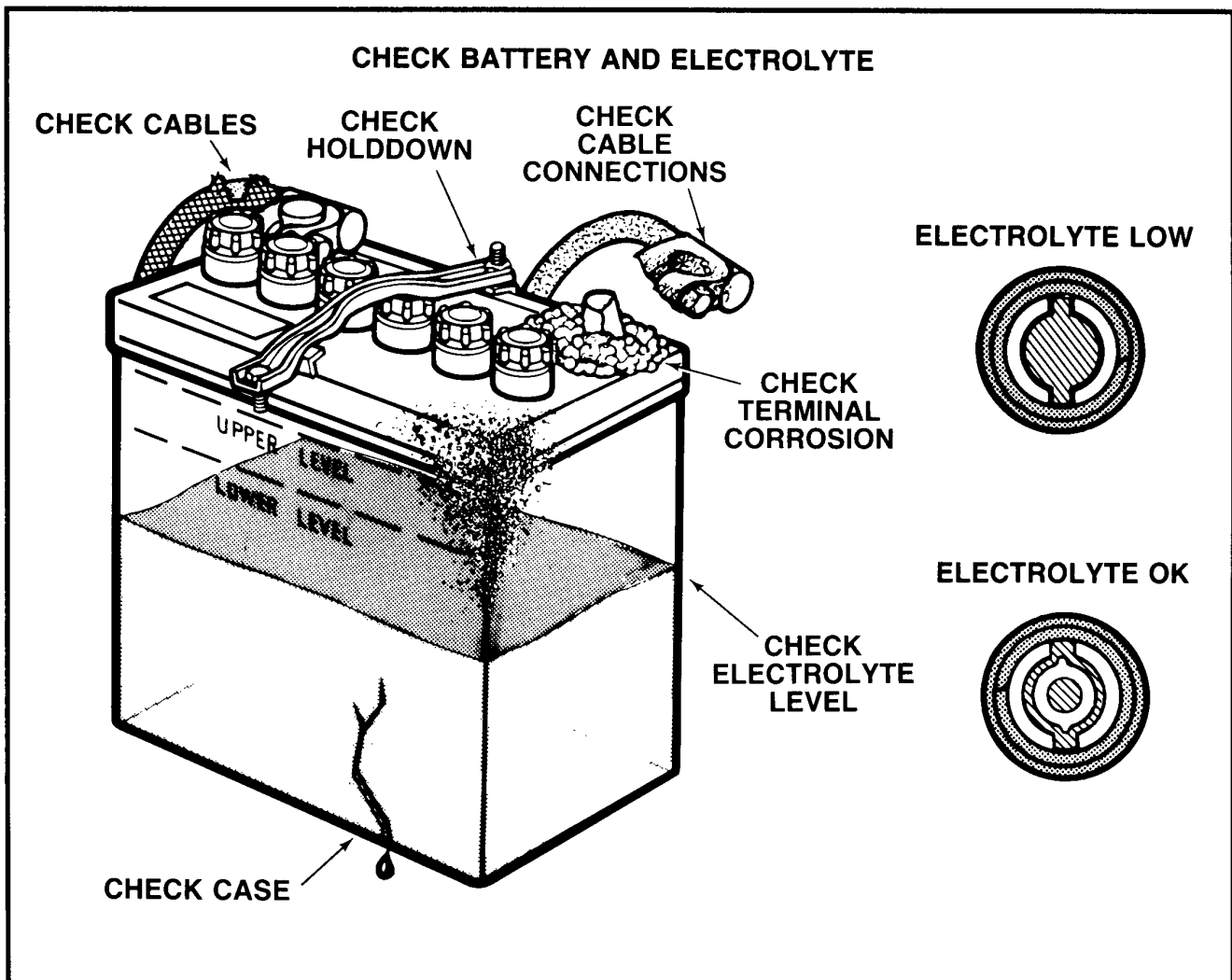

8. Check the tension and condition of the alternator drive belt. A loose belt must be tightened. It will prevent proper charging. A belt too tight will reduce alternator life. It should be loosened to specs. A frayed or glazed belt will fail during operation. Replace it.

NOTE: Approved Equipment tension gauge:  
Nippondenso, BTG-20 (SST) Borroughs BT-33-73F

9. Check for **battery drain** or **parasitic loads** using an ammeter. Connect the ammeter in series between the battery negative terminal and ground cable connector. Toyota vehicles typically show less than .020 amp of current to maintain electronic memories ... a reading of more than .035 amp is unacceptable. If the ammeter reads more than .035 amp, locate and correct the cause of excessive battery drain.

10. Check for battery discharge across the top of the battery using a voltmeter. Select the low voltage scale on the meter, connect the negative (black) test lead to the battery's negative post, and connect the positive (red) test lead to the top of the battery case. If the meter reading is more than 0.5 volt, clean the case top using a solution of baking soda and water.

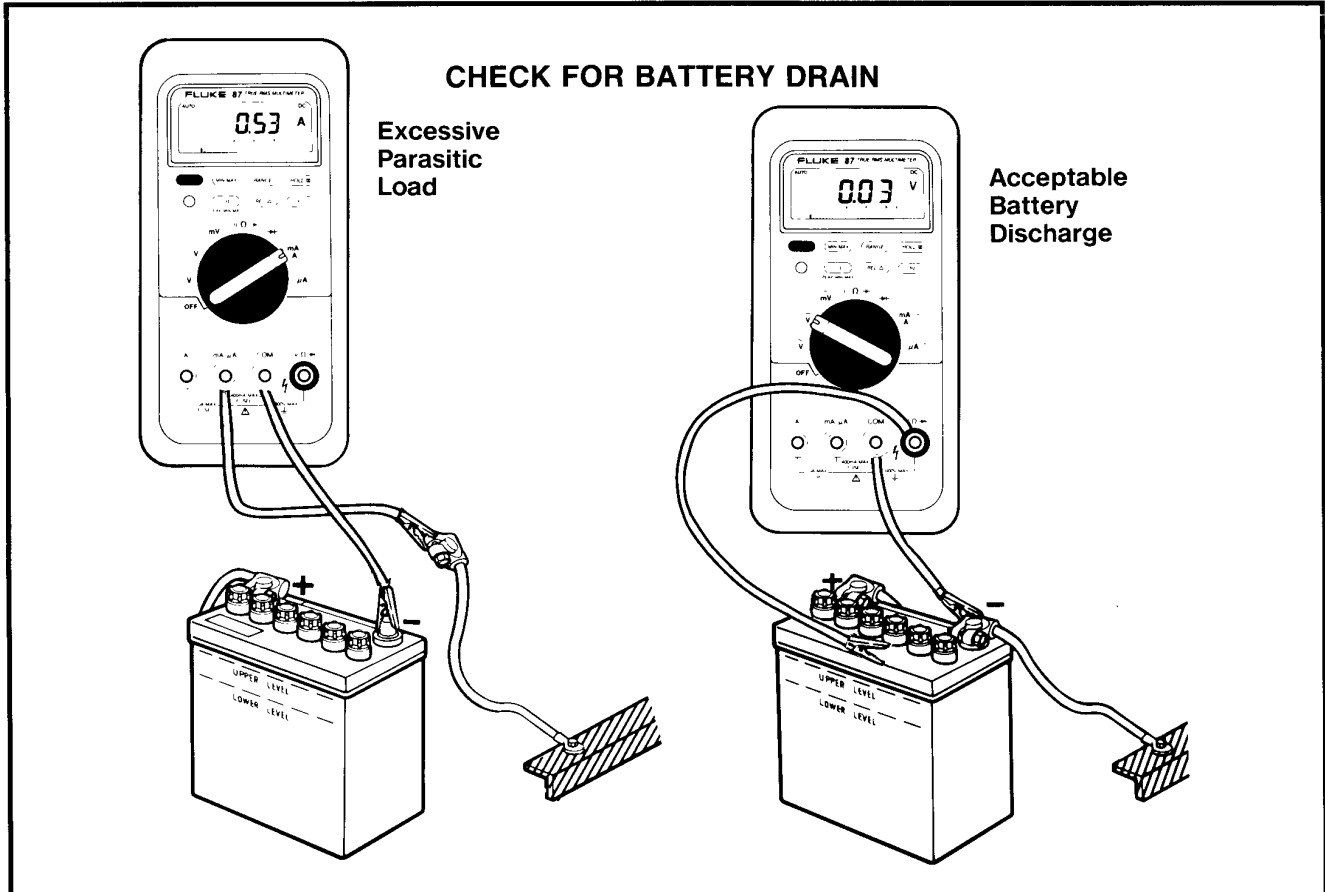
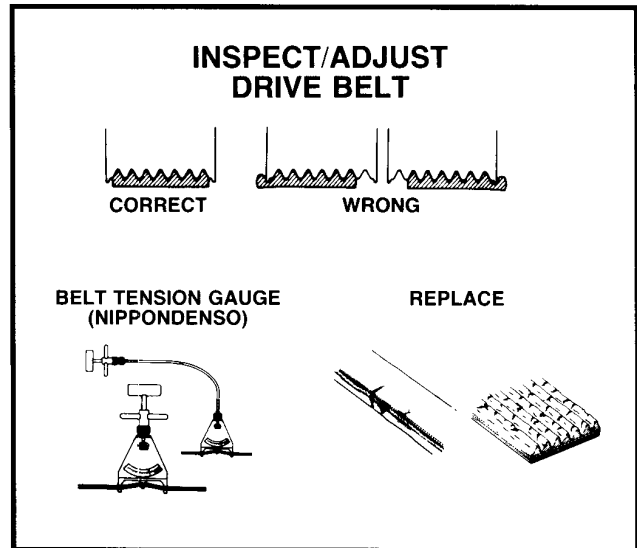

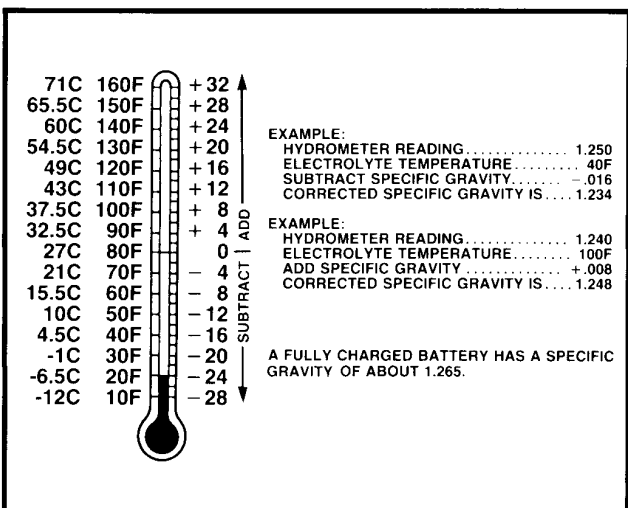
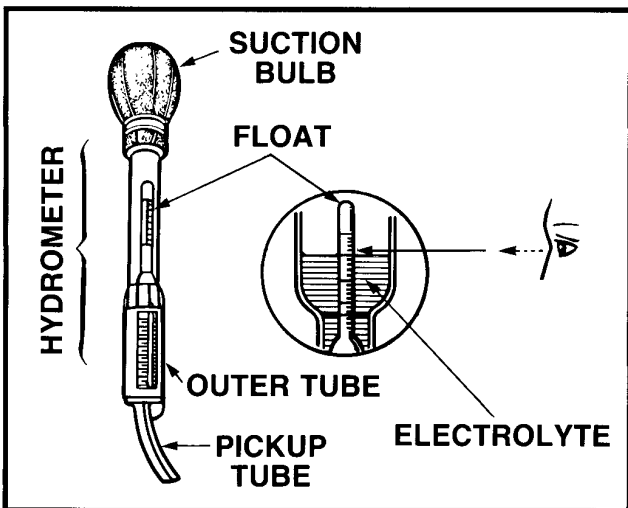
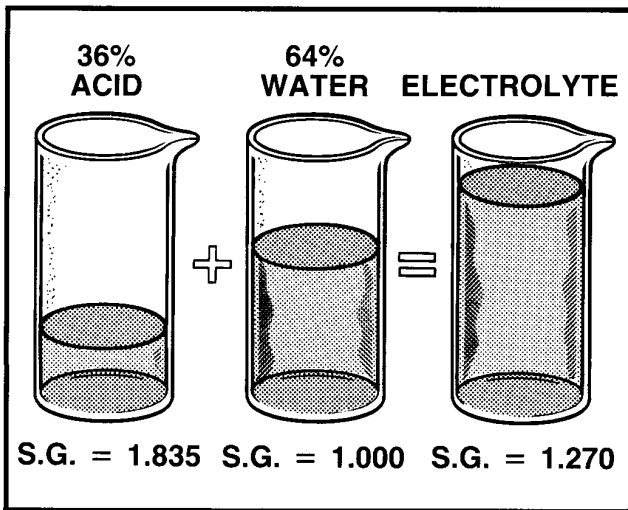

## STATE-OF-CHARGE TEST

The state-of-charge test checks the battery's chemical condition. One method uses a hydrometer to measure the specific gravity of the electrolyte. Another method uses a digital voltmeter to check the battery's open circuit voltage and, for a general indication of the battery's condition, check the indicator eye (if the battery has one) or check the headlamp brightness during starting.

### Specific Gravity

Specific gravity means exact weight. The hydrometer compares the exact weight of electrolyte with that of water. **Strong electrolyte in a charged battery is heavier than weak electrolyte in a discharged battery.**

By weight, the electrolyte in a fully charged battery is about 36% acid and 64% water. The specific gravity of water is 1.000. The acid is 1.835 times heavier than water, so its specific gravity is 1.835. The electrolyte mixture of water and acid has a specific gravity of 1.270 is usually stated as "twelve and seventy."

By measuring the specific gravity of the electrolyte, you can tell if the battery is fully charged, requires charging, or must be replaced. It can tell you if the battery is charged enough for the capacity, or heavy-load test.

**TEST PROCEDURE:** The following steps outline a typical procedure for performing a state-of-charge test:

1. Remove vent caps or covers from the battery cells.
2. Squeeze the hydrometer bulb and insert the pickup tube into the cell closest to the battery's positive (+) terminal.
3. Slowly release the bulb to draw in only enough electrolyte to cause the float to rise. Do not remove the tube from the cell.
4. Read the specific gravity indicated on the float. Be sure the float is drifting free, not in contact with the sides of top of the barrel. Bend down to read the hydrometer a eye level. Disregard the slight curvature of liquid on the float.
5. Read the temperature of the electrolyte.
6. Record your readings and repeat the procedure for the remaining cells.

**TEMPERATURE CORRECTION:** The specific gravity changes with temperature. Heat thins the liquid, and lowers the specific gravity. Cold thickens the liquid, and raises the specific gravity. Hydrometers are accurate at 80-F (26.7°C). If the electrolyte is at any other temperature, the hydrometer readings must be adjusted. Most hydrometers have a built-in thermometer and conversion chart. Refer to the temperature correction chart. For each 1 O°F (5.5°C) above 80°F (26.7°C), ADD 0.004 to your reading.

**TEST RESULTS:** Specific gravity readings tell a lot about battery condition.

1. A fully charged battery will have specific gravity readings around 1.265.
2. Specific gravity readings below 1.225 usually mean the battery is run down and must be charged.
3. Readings around 1.190 indicate that sulfation is about to begin. The battery must be charged.
4. Readings of 1.155 indicate severe discharge. Slow charging is required to restore active materials.
5. Readings of 1.120 or less indicate that the battery is completely discharged. It may require replacement, but slow charging may restore some batteries in this condition.
6. A difference of 50 points (0.050) or more between one or more cells indicates a defective battery. It should be replaced.
7. When the specific gravity of all cells is above 1.190 and the variation between cells is less than 50 points, the battery can be tested under load.

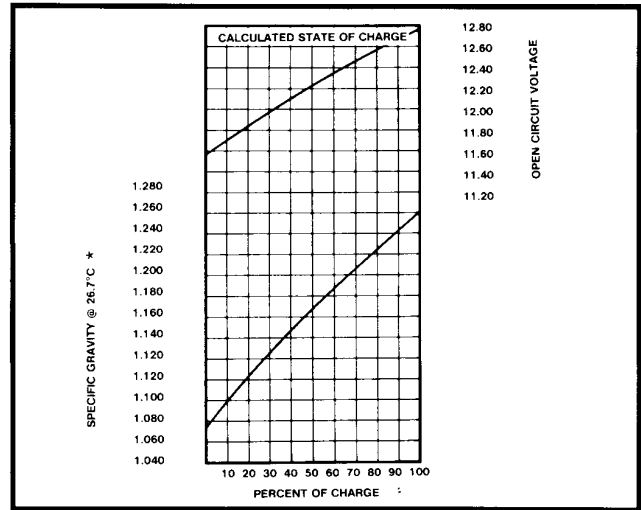

\*Difference between cells should not vary more than 50 points (0.050). If it does, replace the battery.

### Open-Circuit Voltage

An accurate digital voltmeter is used to check the battery's open-circuit voltage:

1. If the battery has just been charged, turn on the headlamps for one minute to remove any surface charge.
2. Turn headlamps off and connect the voltmeter across the battery terminals.
3. Read the voltmeter. A fully charged battery will have an open-circuit voltage of at least 12.6 volts. A dead battery will have an open-circuit voltage of less than 12.0 volts.

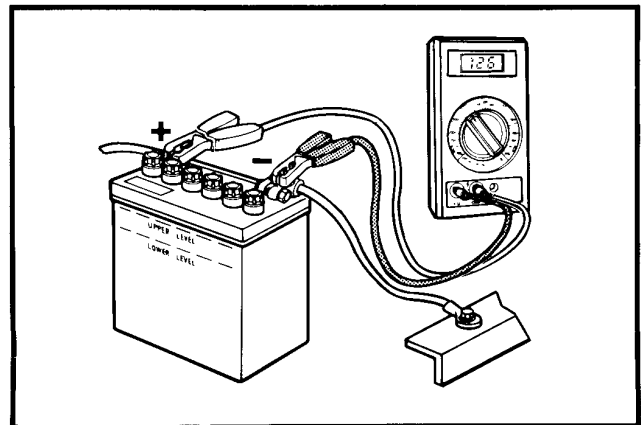

### Indicator Eye

Toyota original-equipment batteries have an indicator eye for electrolyte level and specific gravity. If the eye shows red, the electrolyte level is low or the battery is severely discharged. If some blue is showing, the level is okay and the battery is at least 25% charged.

**NOTE:** The indicator eye should be used only as a general indication of electrolyte level and strength.

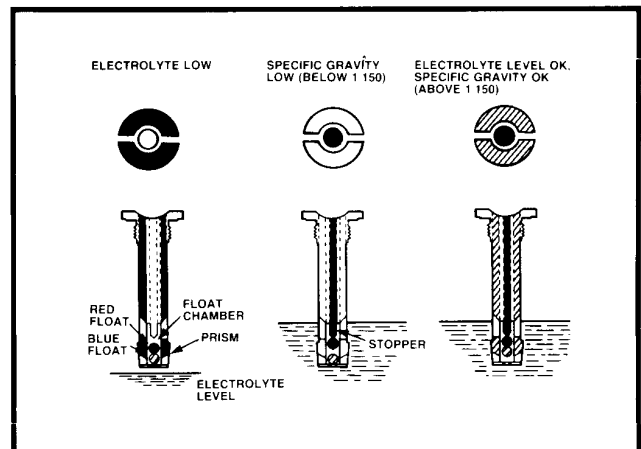

## HEAVY-LOAD TEST

While an open circuit voltage test determines the battery's state of charge, it does not measure the battery's ability to deliver adequate cranking power. A **capacity**, or **heavy-load**, test does. A Sun VAT-40 tester is used. If another type of tester is used, follow the manufacturer's recommended procedure.

The following steps outline a typical procedure for load testing a battery:

1. Test the open circuit voltage. The battery must be at least half charged. If the open circuit voltage is less than 12.2v, charge the battery.
2. Disconnect the battery cables, **ground cable first**.
3. Prepare the tester:
  - Rotate the Load Increase control to OFF.
  - Check each meter's mechanical zero. Adjust, if necessary.
  - Connect the tester Load Leads to the battery terminals; RED to positive, BLACK to negative.
  - Set Volt Selector to INT 18V. Tester voltmeter should indicate battery open-circuit voltage.

**NOTE:** Battery open-circuit voltage should be at least 12.2 volts (50% charged). If not, the battery requires charging.

- Set Test Selector to #2 CHARGING.
  - Adjust ammeter to read ZERO using the electrical Zero Adjust control.
4. Connect the clamp-on Amps Pickup around either tester load cable (disregard polarity).
  5. Set the Test Selector Switch to #1 STARTING.
  6. Load the battery by turning the Load Increase control until the ammeter reads **3 times the amp-hour (AH) rating or one-half the cold-cranking ampere (CCA) rating**.
  7. Maintain the load for **no more than 15 seconds** and note the voltmeter reading.
  8. Immediately turn the Load Increase control OFF.
  9. If the voltmeter reading was 10.0 volts or more, the battery is good. If the reading is 9.6 to 9.9 volts, the battery is serviceable, but requires further testing. Charge and re-test. If the reading was **below 9.6 volts, the battery is either discharged or defective**.

**NOTE:** Test results will vary with temperature. Low temperatures will reduce the reading. The battery should be at operating temperature.

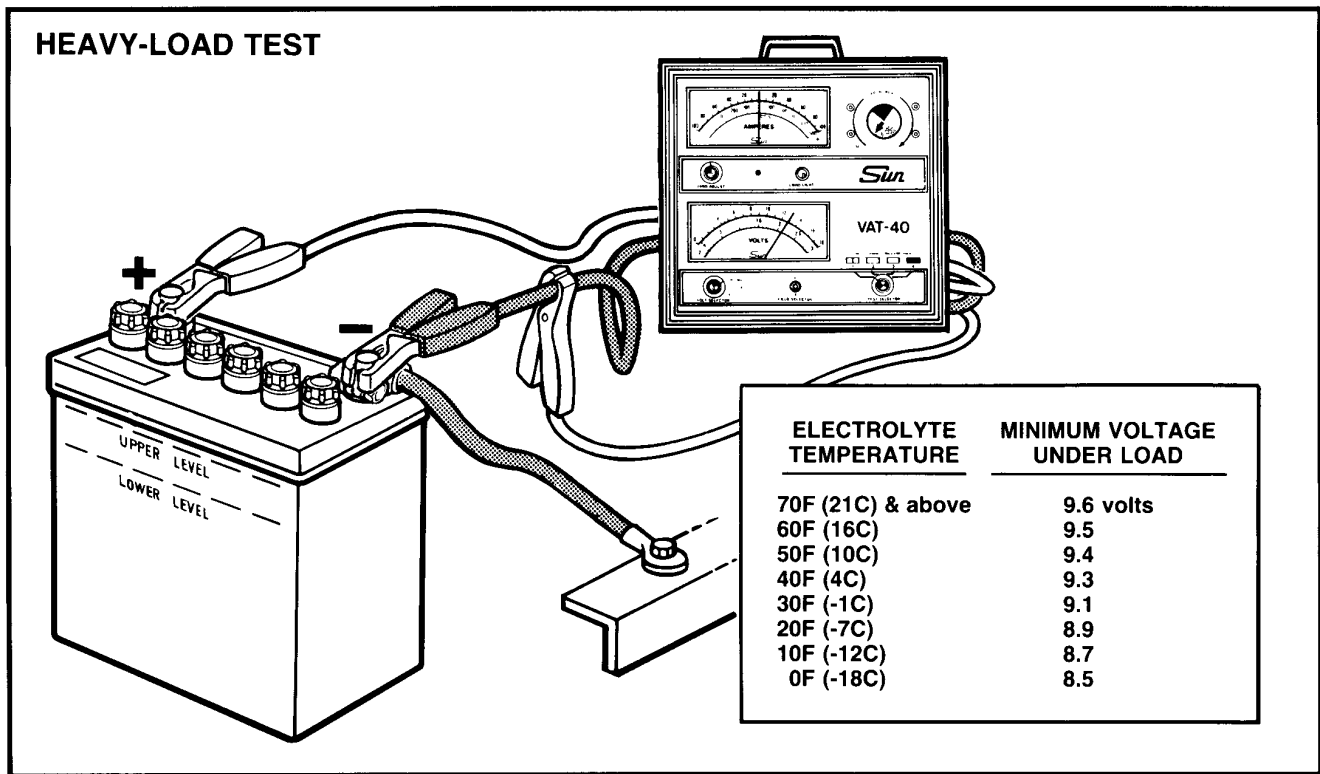

## VISUAL INSPECTION

A visual inspection of the starting system can uncover a number of simple, easy-to-correct problems.

• **SAFETY FIRST:** The same safety considerations used in checking the battery apply here. Remove rings, wristwatch, other jewelry that might contact battery terminals. Wear safety glasses and protective clothing. Be careful not to spill electrolyte and know what to do if electrolyte gets in your eyes, on your skin or clothing, or on the car's finish. Write down programmed settings on electronic components. Avoid causing sparks.

• **STARTING PERFORMANCE:** Check the starting performance. Problem symptoms, possible causes, and needed actions are shown in the chart on the previous page.

• **BATTERY CHECKS:** Inspect the battery for corrosion, loose connections. Check the electrolyte level, condition of the plates and separators, and state of charge (specific gravity or open-circuit voltage). Load test the battery. It must be capable of providing at least 9.6 volts during cranking.

• **STARTER CABLES:** Check the cable condition and connections. Insulation should not be worn or damaged. Connections should be clean and tight.

• **STARTER CONTROL CIRCUIT:** Check the operation of the ignition switch. Current should be supplied to the magnetic switch when the ignition is "on" and the clutch switch or neutral start switch is closed. Faulty parts that prevent cranking can be located using a remote-control starter switch and a jumper wire. Use the "split half" diagnosis method. Ohmmeter checks can also identify component problems.

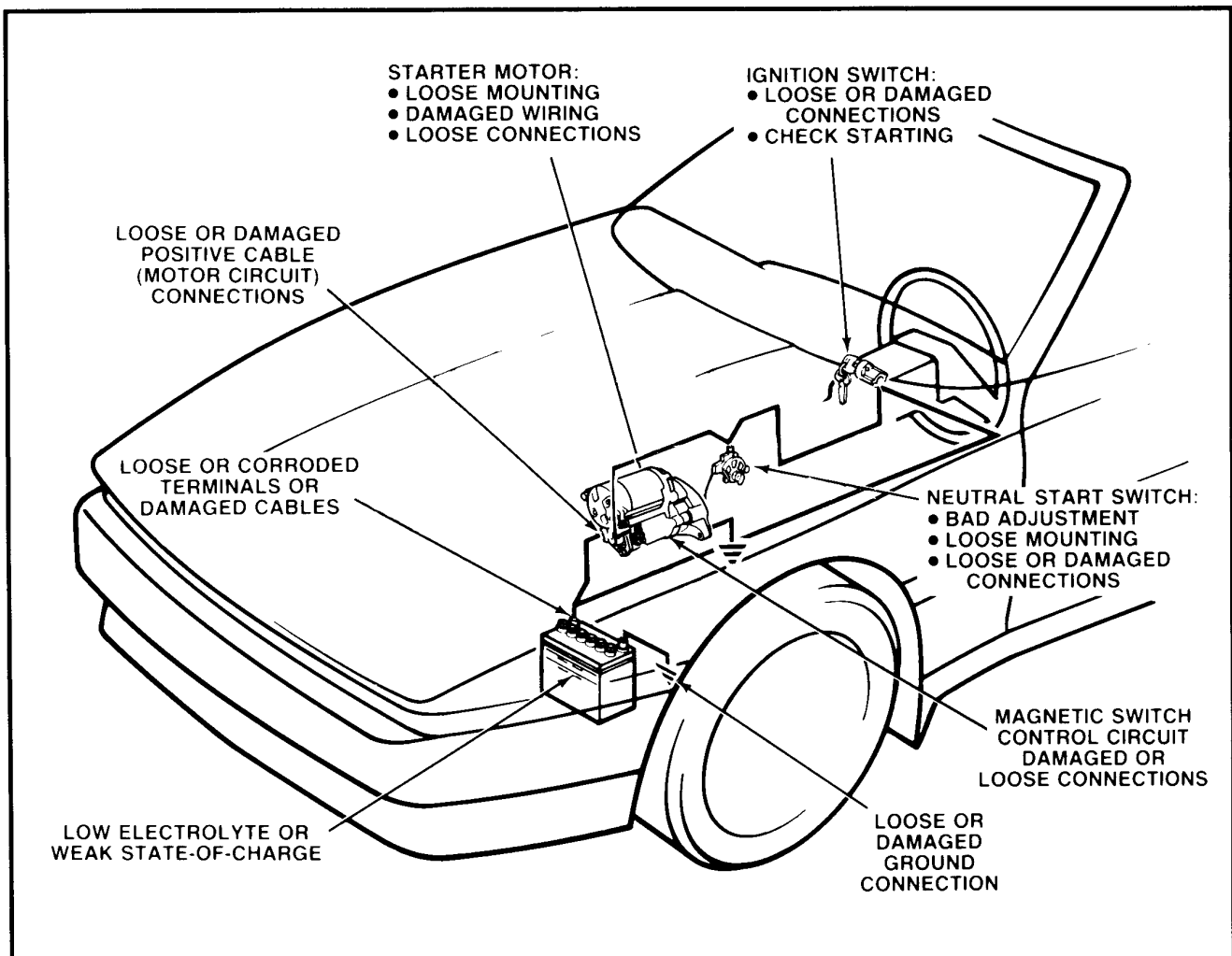

## CURRENT DRAW TEST

A starter current draw test provides a quick check of the entire starting system. With the Sun VAT-40 tester, it also checks battery's cranking voltage. If another type of tester is used, follow the manufacturer's recommended procedure.

The starting current draw and cranking voltage should meet the specifications listed for the Toyota model being tested. Typical current draw specs are 130-150 amps for 4-cylinder models and 175 amps for 6-cylinder models. Cranking voltage specs range from 9.6 to 11 volts. Always refer to the correct repair manual. Only perform the test with the engine at operating temperature.

The following steps outline a typical procedure for performing a current draw test on a starting system:

1. This test should be made only with a serviceable battery. The specific gravity readings at 80°F should average at least 1.190 (50% charged). Charge the battery, if necessary.

2. Prepare the tester:

- Rotate the Load Increase control to OFF.
- Check each meter's mechanical zero. Adjust, if necessary.
- Connect the tester Load Leads to the battery terminals; RED to positive, BLACK to negative.

**NOTE:** Battery open-circuit voltage should be at least 12.2 volts (50% charged). If not, the battery requires charging.

- Set Volt Selector to INT 18V. Tester voltmeter should indicate battery open-circuit voltage.
  - Set Test Selector to #2 CHARGING.
  - Adjust ammeter to read ZERO using the electrical Zero Adjust control.
3. Connect the clamp-on Amps Pickup around the battery ground cable or cables.
  4. Make sure all lights and accessories are off and vehicle doors are closed.
  5. Set the Test Selector switch to #1 STARTING.
  6. Disable the ignition so the engine does not start during testing.
  7. Crank the engine, while observing the tester ammeter and voltmeter.
    - Cranking speed should be normal (200-250 rpm).
    - Current draw should not exceed the maximum specified.
    - Cranking voltage should be at or above the minimum specified.
  8. Restore the engine to starting condition and remove tester leads.

**TEST RESULTS:** High current draw and low cranking speed usually indicate a faulty starter. High current draw may also be caused by engine problems. A low cranking speed with low current draw, but high cranking voltage, usually indicates excessive resistance in the starter circuit. Remember that the battery must be fully charged and its connections tight to insure accurate results.

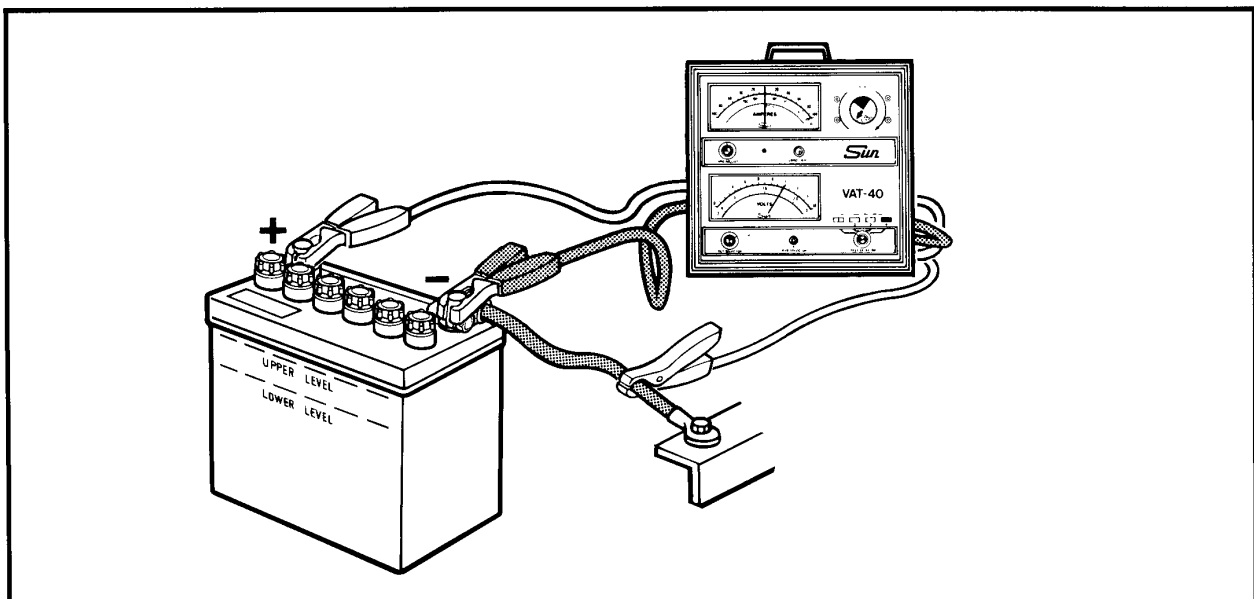

## VOLTAGE-DROP TESTS

Voltage-drop testing can detect excessive resistance in the starting system. High resistance in the starter motor circuit (power side or ground side) will reduce current to the starting motor. This can cause slow cranking speed and hard starting. High resistance in the starter control circuit will reduce current to the magnetic switch. This can cause improper operation or no operation at all.

A Sun VAT-40 tester or separate voltmeter can be used. The following steps outline a typical procedure for performing voltage-drop tests on the starting system:

### Motor Circuit (insulated Side)

1. If using the Sun VAT-40, set the Volt Selector to EXT 3V. For other voltmeters, use a low scale.
2. Connect the voltmeter leads ... RED to the battery positive (+) terminal, BLACK to terminal "C" on the starter motor magnetic switch.

3. Disable the ignition so the engine cannot start during testing.

NOTE: On models with the Integrated Ignition Assembly, disconnect the "IIA" plug. On others, disconnect the power plug to the remote igniter assembly (black-orange wire).

4. Crank the engine and observe the voltmeter. Less than 0.5 volt indicates acceptable resistance. More than 0.5 volt indicates excessive resistance. This could be caused by a damaged cable, poor connections, or a defective magnetic switch.
5. If excessive resistance is indicated, locate the cause. Acceptable voltage drops are 0.3 volt across the magnetic switch, 0.2 volts for the cable, and zero volts for the cable connection. Repair or replace components, as needed.

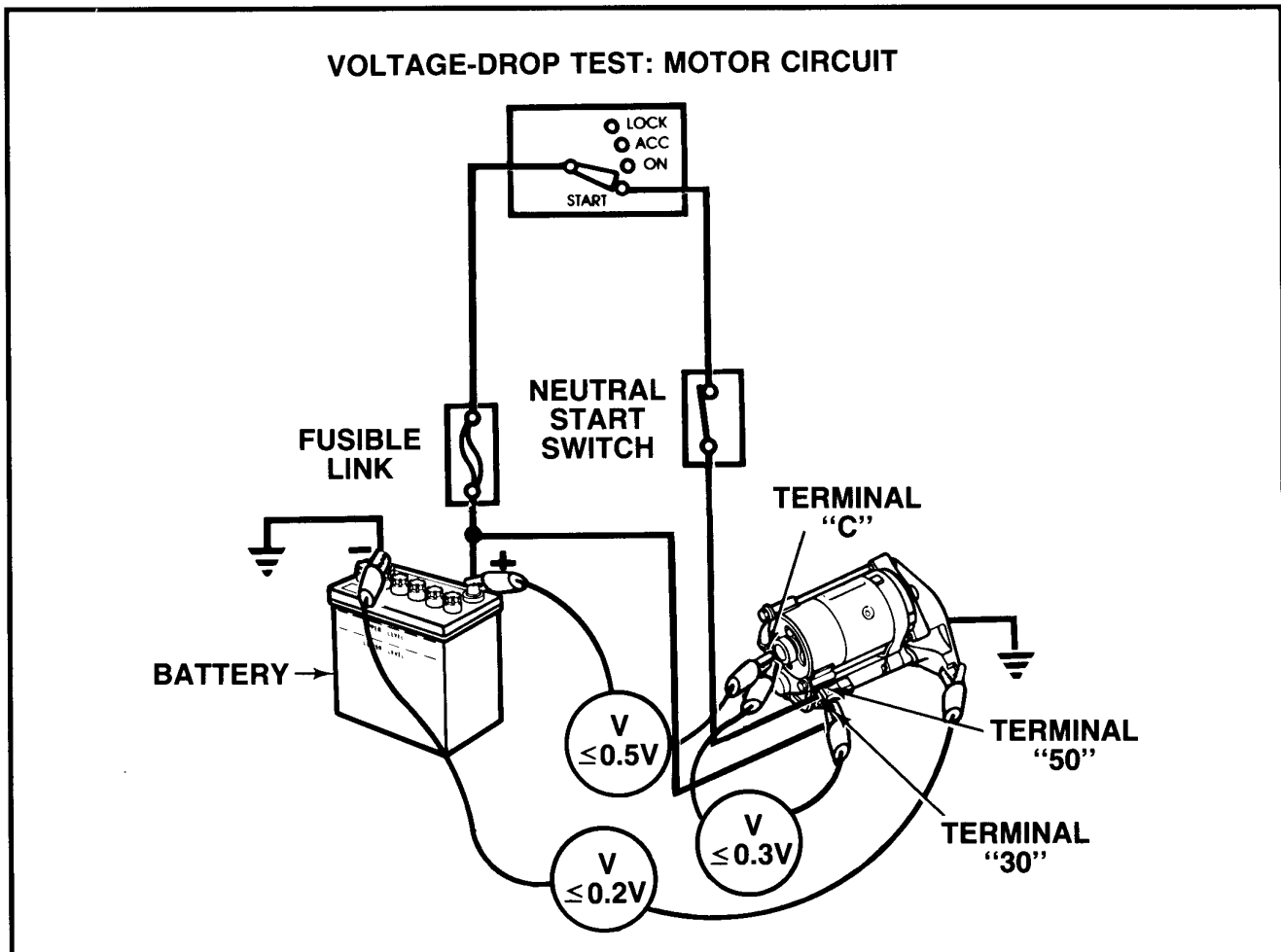

## Motor Circuit (Ground Side)

1. Connect the voltmeter leads ... RED to the starter motor housing, BLACK to the battery ground (-) terminal.
2. Crank the engine and observe the voltmeter. Less than 0.2 volt indicates acceptable resistance. More than 0.2 volt indicates excessive resistance. This could be caused by a loose motor mount, a bad battery ground, or a loose connection. Repair or replace components as necessary. Make sure engine-to-body ground straps are secure.

## Control Circuit

1. Connect the voltmeter leads ... RED to the battery positive (+) terminal, BLACK to terminal "50" of the starting motor.
2. On vehicles with automatic transmission, place the lever in Park or Neutral. On vehicles with manual transmission, depress the clutch.

(NOTE: A jumper wire could be used to bypass either of these switches).

3. Crank the engine and observe the voltmeter. Less than .5 volt is acceptable. If the current draw was high or cranking speed slow, the starter motor is defective. More than .5 volt indicates excessive resistance. Isolate the trouble and correct the cause.
4. Check the neutral start switch or clutch switch for excessive voltage drop. Also check the ignition switch. Adjust or replace a defective switch, as necessary.
5. An alternate method to checking the voltage drop across each component is to leave the voltmeter connected to the battery (+) terminal and move the voltmeter negative lead back through the circuit toward the battery. The point of high resistance is found between the point where voltage drop fell within specs and the point last checked.

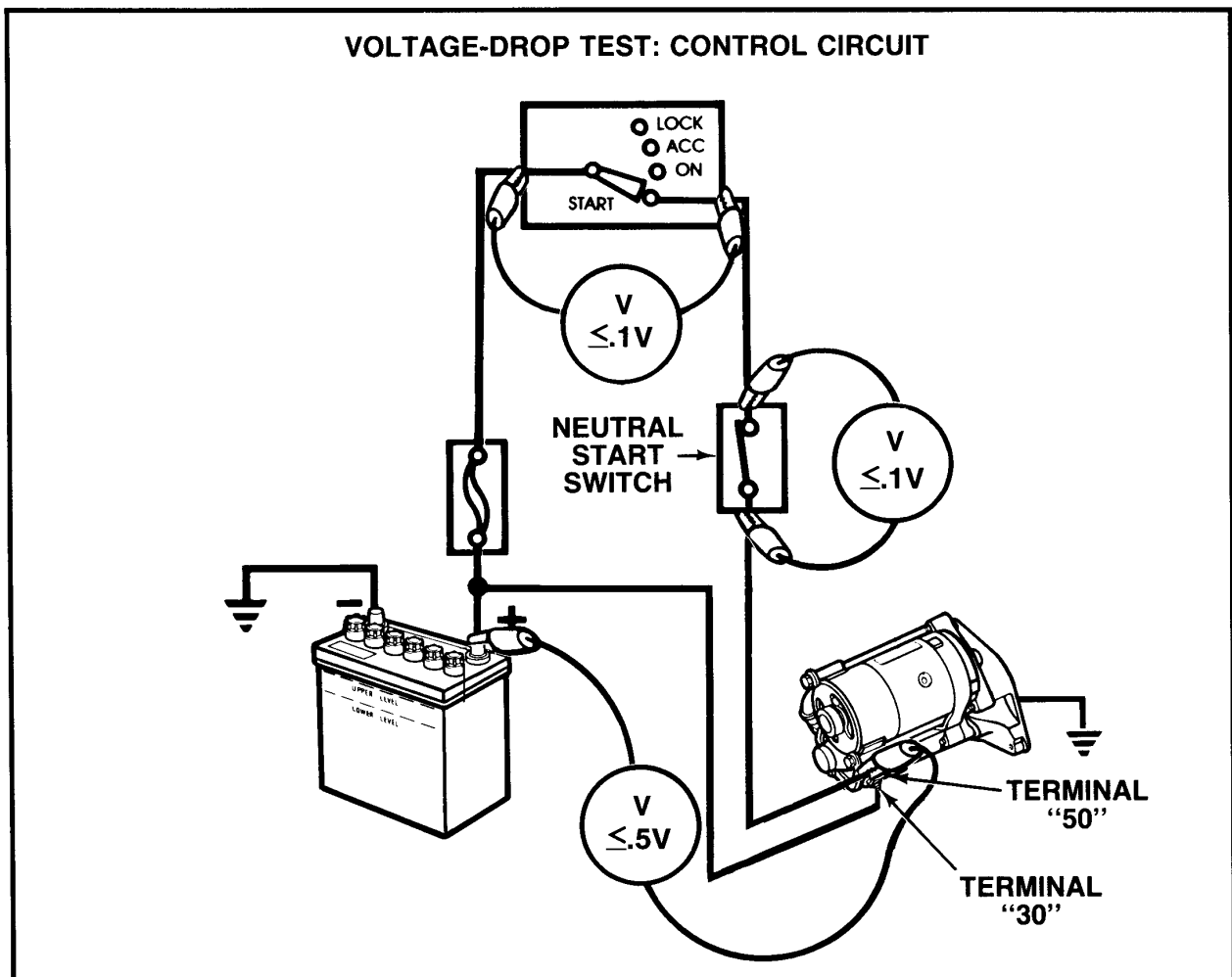

## VISUAL INSPECTION

A visual inspection should always be your first step in checking the charging system. A number of problems that would reduce charging performance can be identified and corrected.

## CHECK THE BATTERY

- Check for proper electrolyte level and state of charge. When fully charged, **specific gravity should be between 1.25 and 1.27 at 80°F (26.7°C).**
- Check the battery terminals and cables. The terminals should be free of corrosion and the cable connections tight.

## CHECK THE FUSES AND FUSIBLE LINK

- Check the fuses for continuity. These include the **Engine fuse (10A), Charge fuse (7.5A), and Ignition fuse (7.5A).**
- Check the fusible link for continuity.

## INSPECT THE DRIVE BELT

- Check for belt separation, cracks, fraying, or glazing. If necessary, replace the drive belt.
- Check the drive belt tension using the proper tension gauge, Nippondenso BTG-20

Refer to the appropriate repair manual for proper drive belt tension. "New" belts (used less than 5 minutes on a running engine) are installed with greater tension than "used" belts. Tension specs are different for different models.

## INSPECT THE ALTERNATOR

- Check the wiring and connections. Replace any damaged wires, tighten any loose connections.
- Check for abnormal noises. Squealing may indicate drive belt or bearing problems. Defective diodes can produce a whine or hissing noise because of a pulsating magnetic field and vibration.

## CHECK THE WARNING LAMP CIRCUIT

- With the engine warm and all accessories off, turn the ignition to ON. The warning lamp should light.
- With the engine started and the ignition in RUN, the warning lamp should be off.
- If the lamp does not operate as specified, check the bulb and check the lamp circuit.

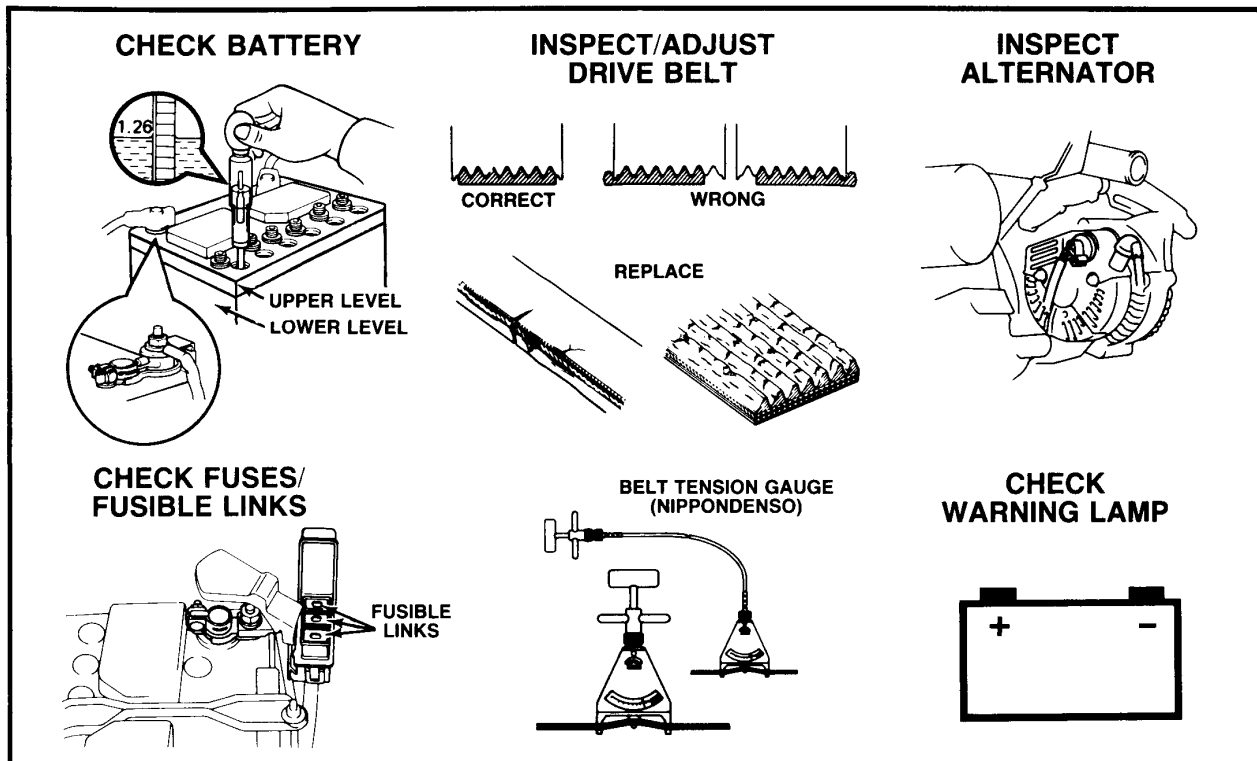

## ALTERNATOR OUTPUT TEST

The alternator output test checks the ability of the alternator to deliver its rated output of voltage and current. This test should be performed whenever an overcharging or undercharging problem is suspected. Output current and voltage should meet the specifications of the alternator. If not, the alternator or regulator (IC or external) may require replacement.

A Sun VAT-40 tester, similar testers, or a separate voltmeter and ammeter can be used. Toyota repair manuals detail the testing procedures with an ammeter and voltmeter. Follow the manufacturer's instructions when using special testers, although most are operated similarly. The following steps outline a typical procedure for performing the alternator output test using a Sun VAT-40:

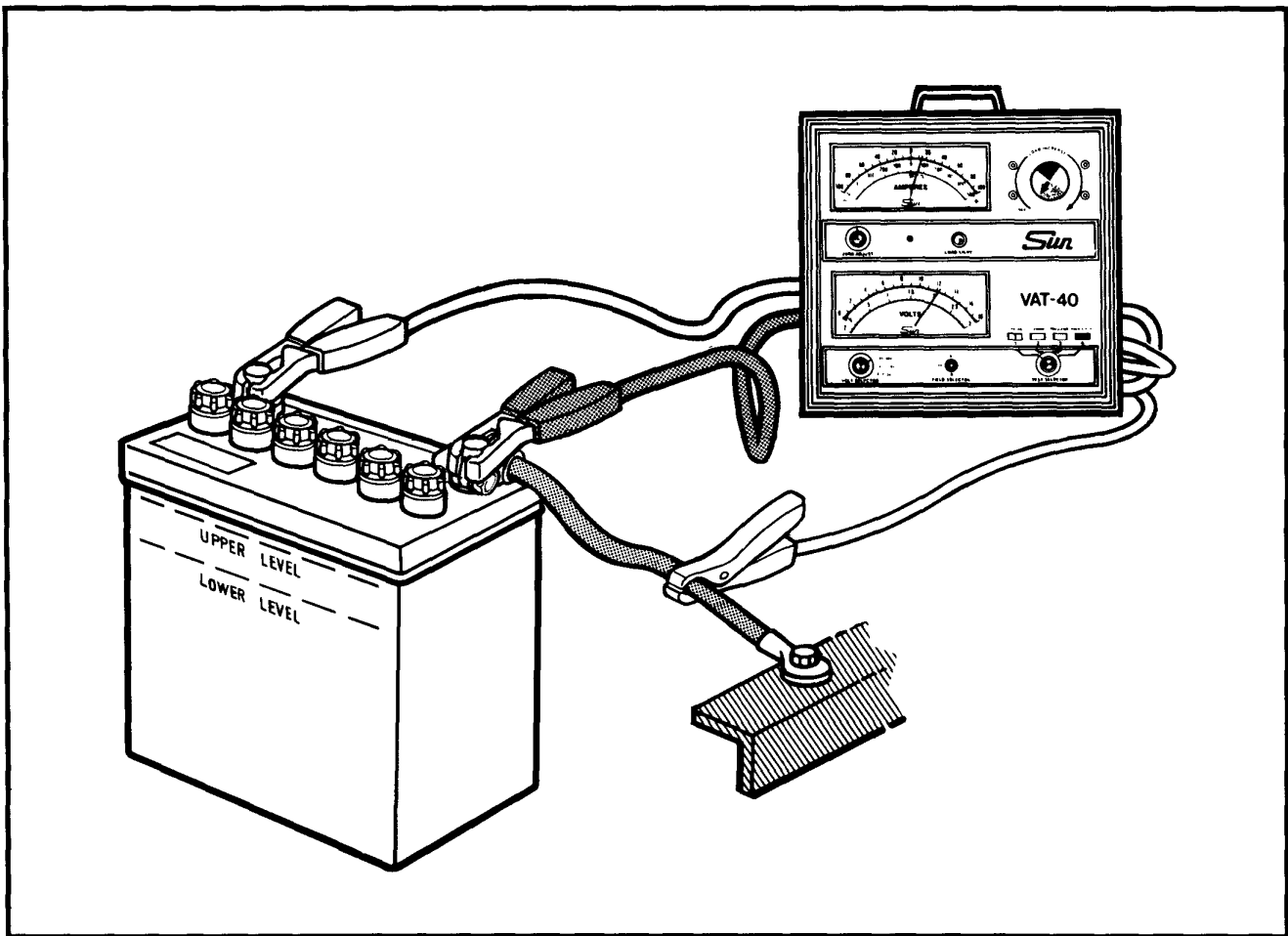

## Charging Without Load

1. Prepare the tester:

- Rotate the Load Increase control to OFF,
- Check each meter's mechanical zero. Adjust, if necessary.
- Connect the tester Load Leads to the battery terminals; RED to positive, BLACK to negative.
- Set Volt Selector to INT 18V.
- Set Test Selector to #2 CHARGING.
- Adjust ammeter to read ZERO using the electrical Zero Adjust control.
- Connect the clamp-on Amps Pickup around the battery ground (-) cables.

2. Turn the ignition switch to "ON" (engine not running) and read the amount of discharge on the ammeter. This is a base reading for current the alternator must supply for ignition and accessories **before** it can provide current to charge the battery.

**NOTE: The reading should be about six amps.**

3. Start the engine and adjust the speed to about 2000 rpm. Some models may require a different speed setting.

4. After about 3-4 minutes, read the ammeter and

voltmeter. Add this ammeter reading and the reading found in step 2 (engine not running).

**NOTE: The total current should be less than 10 amps. If it is more, the alternator may still be charging the battery. Once the battery is fully charged, you should get specified results.**

The voltage should be within the specs for the alternator. This is usually between 13 and 15 volts. Refer to the appropriate repair manual. If the voltage is more than specified, replace the regulator. If the voltage is less than specified, ground the alternator field terminal "F" and check the voltmeter reading. This bypasses the regulator, so do not exceed the specified test speed. If the reading is still less than specified, check the alternator.

5. Remove ground from terminal "F."

## Charging With Load

6. With the engine running at specified speed, adjust the Load Increase control to obtain the highest ammeter reading possible without causing the voltage to drop lower than 12 volts.

7. Read the ammeter.

**NOTE: The reading should be within 10% of the alternator's rated output. If it is less, the alternator requires further testing or replacement.**

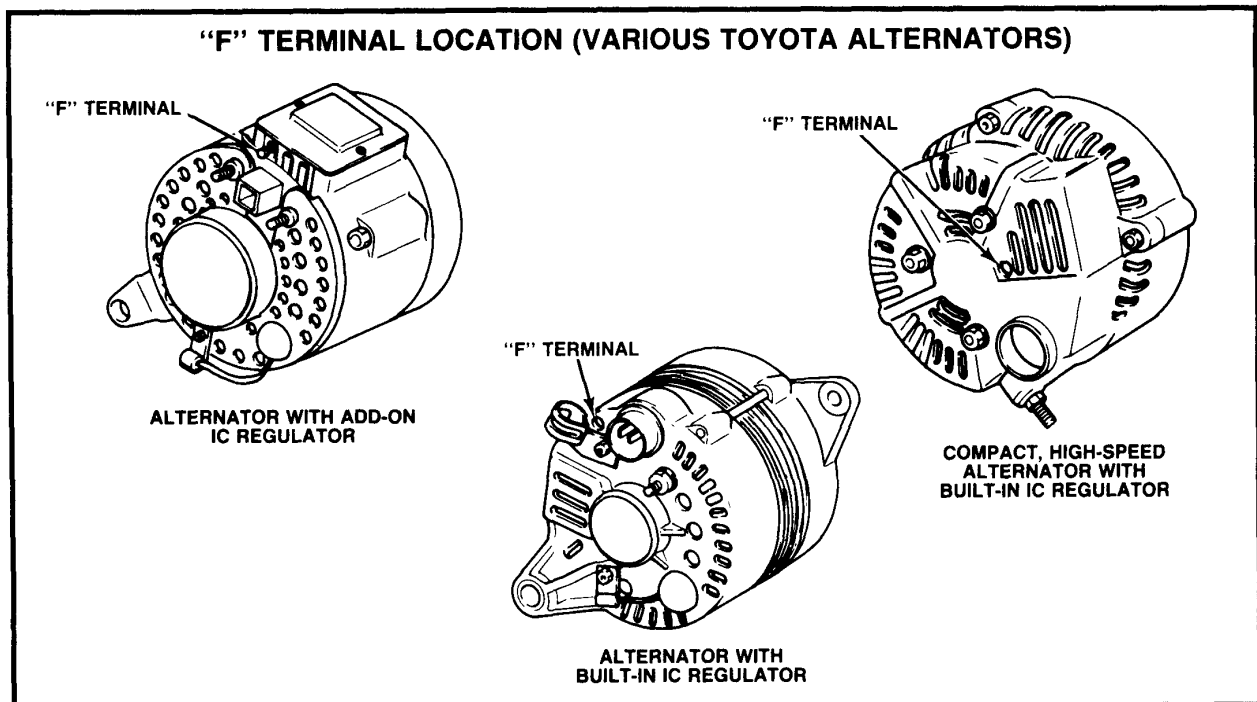

## VOLTAGE-DROP TESTS

Voltage-drop testing can detect excessive resistance in the charging system. These tests determine the voltage drop in the alternator output circuit. Both sides of the circuit should be checked ... insulated side as well as ground side.

Excessive voltage drop caused by high resistance in either of these circuits will reduce the available charging current. Under heavy electrical loads, the battery will discharge.

A Sun VAT-40 tester or a separate voltmeter can be used. The following steps outline a typical procedure for performing voltage-drop tests using a voltmeter:

### Output Circuit - Insulated Side

1. Connect the voltmeter positive lead to the alternator's output terminal "B" and the voltmeter's negative lead to the battery's positive (+) terminal.

2. Start the engine and adjust the speed to approximately 2000 rpm.
3. Read the voltmeter. The voltage drop should be less than 0.2 volt. If it is more, locate and correct the cause of the high resistance.

### Output Circuit - Ground Side

1. Connect the voltmeter's negative lead to the alternator's frame and the voltmeter's positive lead to the battery's negative (-) terminal.
2. Start the engine and run at specified speed (about 2000 rpm).
3. Read the voltmeter. The voltage drop should be 0.2 volt or less. If it is more, locate and correct the cause of high resistance. Excessive resistance is most likely caused by loose or corroded connections.

